

## Power Amplifier Network Module

IP-100XI

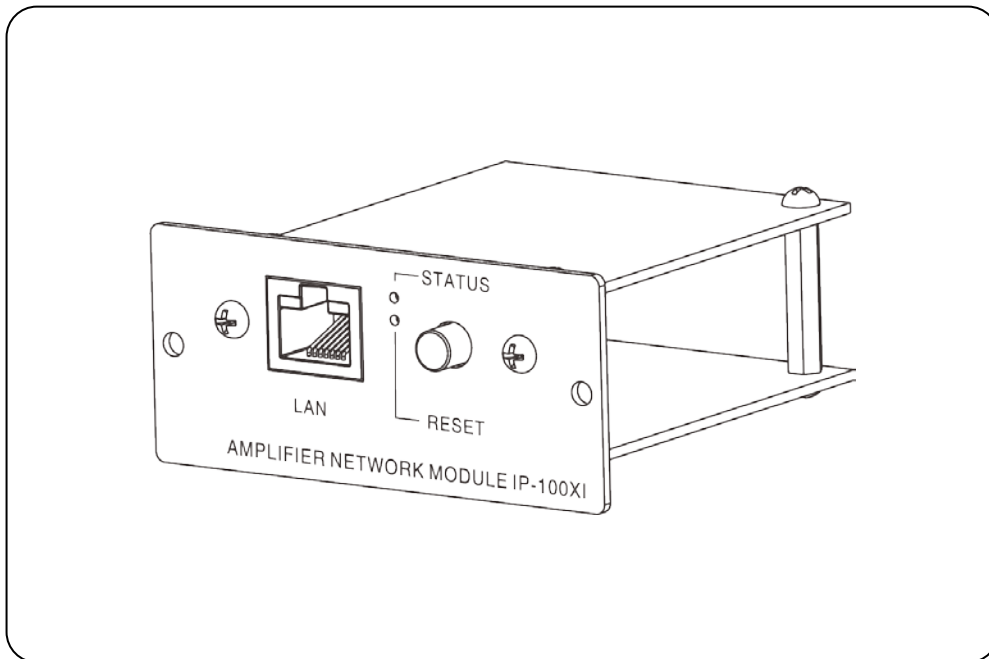

Thanks for your purchase of TOA products IP-1000 series.

Please read the manual carefully to ensure the machine operating in long time and fault-free.

# ***Chapter 1***

---

## ***Safety Precaution***

## Chapter 1: safety precaution

Please abide by the warning and the relevant safety tips.

Please take this manual in convenient place after you reading the guide for future reference.

### Warning

 **The sign means there is potential safety hazard, when operate wrong may result in death or serious injury.**

 **The sign is used to remind the user that attached is the important operation and maintenance data.**

(1) Avoid getting the device wet.

Do not make the machine wet or expose to rain water or other liquid contamination of the environment, or lead to fire or get an electric shock.

(2) Do not use unspecified voltage.

Using the marked voltage on the machine.

Using more than the logo of voltage could lead to fire or shock.

(3) Do not scratch the power cord.

Do not scratch the power cord or cut it.

Simultaneously, keep the power line far way from heated objects, put heavy things on it will lead to fires or electric shock.

### Using machine

(1) In case of the anomalies

Please turn off the power supply immediately when finding the abnormal phenomena, please connect with the agency. If you continue to using the equipment, it is likely to catch on fire or resulted in electric shock.

- The smoke or smell of the machine.
- The inside of the machine is flooded by water or external intrusion.
- Machine falling or machine case damage.
- The power cord damage (wire core is exposed of broken, etc)
- Malfunction (e.g. no network connection, no sound etc.)

(2) Do not open the machine internal or modify the machine.

Do not external substance getting into the equipment.

Please do not put any metallic or inflammable objects into the machine, otherwise it may cause fires or electric shock.

(3) Please do not touch it during thundering

To avoid electric shock, please do not touch the machine and the plug during lightning, etc.

(4) Please do not place containers with liquid or small metal objects on the machine above.

If containers drop and liquid get into to the machine that will likely catch fires or cause electric shock.

(5) Do not open the machine internal or modify the machine.

The machine internal contains high voltage parts, once open the cover or modify the machine, it may result in fires or cause shock. All the maintenance and other machine modification should be operated by professional personnel.

(6) Maintenance and the precautions for not using in a long time.

While maintenance, if the machine is not been used for 10 days or more, please turn off power supply switch for safety. If do not comply with this provision, it will likely cause electric shock or fires.

## ***Chapter 2***

---

### ***Products Description***

#### 2.1 Summary

IP-100XI is a power amplifier network module, which can be installed in the specific amplifier product to add in the network functions, it can receive broadcast from other terminals and servers and it supports system setting via browser.

- ◆ Receiving broadcast

The IP power amplifier module can receive broadcast from other terminals and servers.

- ◆ Timing program

Uploading every day sound source to the server, programming the broadcasting plan, the IP power amplifier module can broadcast the server configuration plan automatically.

- ◆ Broadcasting IP

When the amplifier module is connected to power but not the LAN cable, pressing the reset button quickly will automatically broadcasting the IP and subnet mask parameters information.

- ◆ System setting via browser

User can set network and audio parameters, modify login password via browser to realize the customized configuration.

- ◆ Amplifier protection and amplifier failure information feedback.

Power amplifier network module can receive input information of amplifier protection and failure, the server will be synchronized window display information of amplifier protection or fault.

## Chapter 2: Products Description

### 2.2 Interface Description

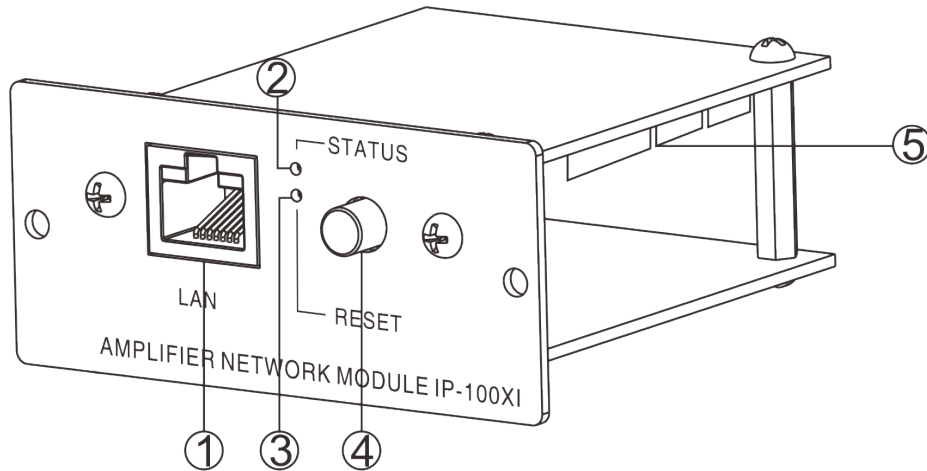

①LAN: network interface

②STATUS: status indicator light

Online: the green light always be ON; Offline: the red light flash slowly; Receiving broadcast: the green light flash quickly; Updating firmware: both green and red light are flash quickly.

③RESET: pressing the key to restore factory defaults IP (or update firmware), broadcasting IP.

Status	Operation
Restore IP address	Connect to power, pressing the key for 3 sec
Enter into the update firmware page.	Press the key for 5 seconds, then connect the power
Broadcasting IP	Connect to power but not connecting LAN cable, short pressing and releasing.

④VOLUME knob: controls input volume.

⑤Internal interface: the diagram as follows:

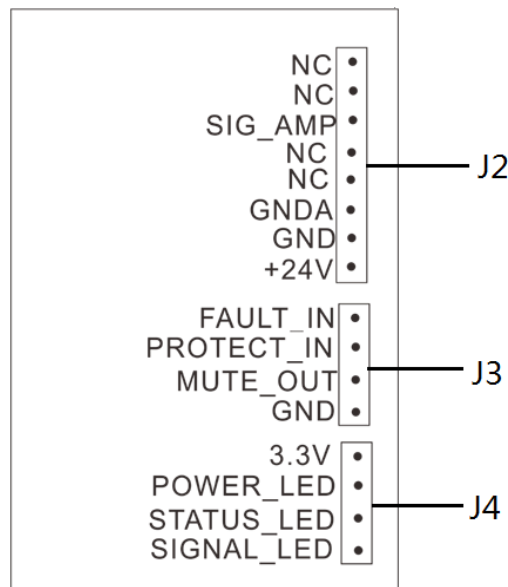

## Chapter 2: Products Description

### 2.2 Interface description

Interface	Remarks	Description
J2	+24V	Power input, nominal input DC24V/150mA, the maximum range DC15~30V
	GND	Reference to the power input
	GND_A	Reference to the audio signal
	SIG_AMP	Amplifier audio signal input, 1Vrms/600Ω, imbalance.
J3	GND	Reference to the control signal
	MUTE_OUT	Amplifier mute control output: triode collector open circuit output, broadcast open is for low level, broadcast close is for high resistance. The max electric current: 10mA, the max withstand voltage: DC24V.
	PROTECT_IN	Amplifier protection detection input: MCU input, low level effectively, open circuit voltage: 3.3V, 10K resistance up to 3.3V.
	FAULT_IN	Amplifier fault detection input: MCU input, low level effectively, open circuit voltage: 3.3V, 10K resistance up to 3.3V.
J4	3.3V	3.3V interface of power indicator light
	POWER_LED	The interface of power indicator light
	STATUS_LED	Status light interface, offline is for light OFF, login is for light ON.
	SIGNAL_LED	The interface of signal indicator light

#### Amplifier failure and protection

PROTECT and GND can receive amplifier protection information and it will send to the server. Server will pop up a page and display the amplifier protection information after the amplifier protection signal well received.

#### Amplifier failure detection

FAULT\_IN and GND can receive amplifier failure detection signal and it will send to the server. After receiving the amplifier protection information, the server will pop up a page and display the amplifier failure detection information.

#### Mute control

MUTE\_OUT and GND can output the mute signal to other modules or terminals. The power amplifier network module output the mute control signal in the broadcasting, no mute control signal output in free status.

## ***Chapter 3***

---

### ***Wiring***



### 3.1 Wiring diagram

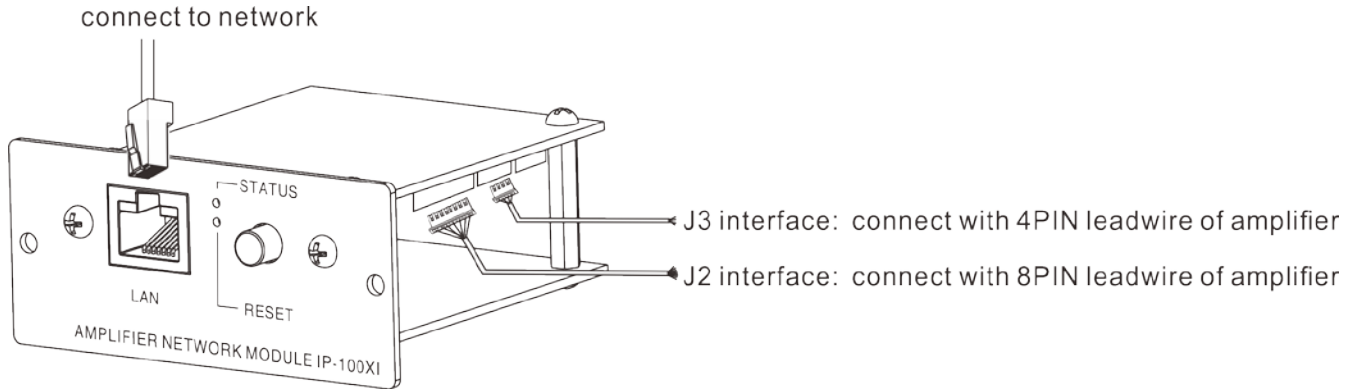

J4 interface: reserved interface.

**3.2 Installation Description**

Using screws to fix IP amplifier module in the slot, as the following picture.

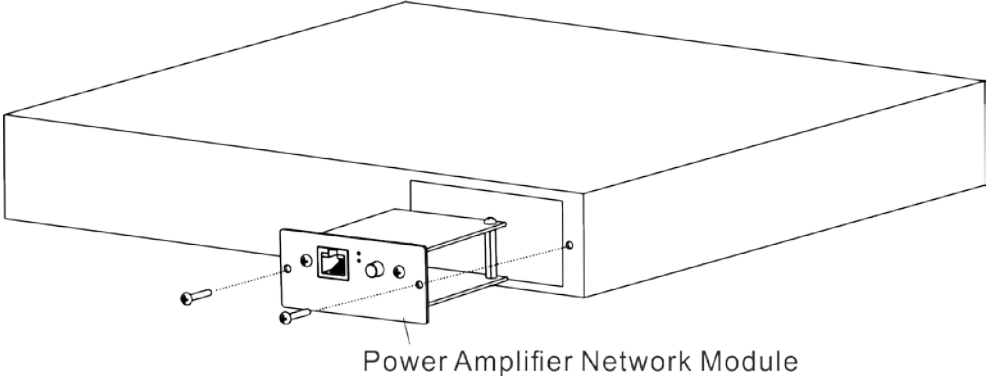

3.3 Reference size(unit: mm)

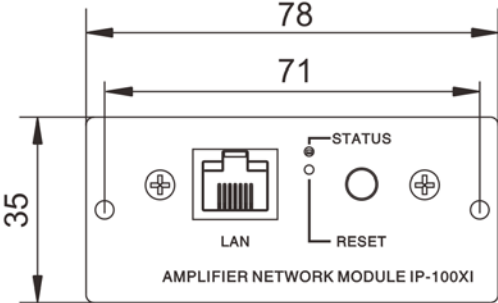

Front view

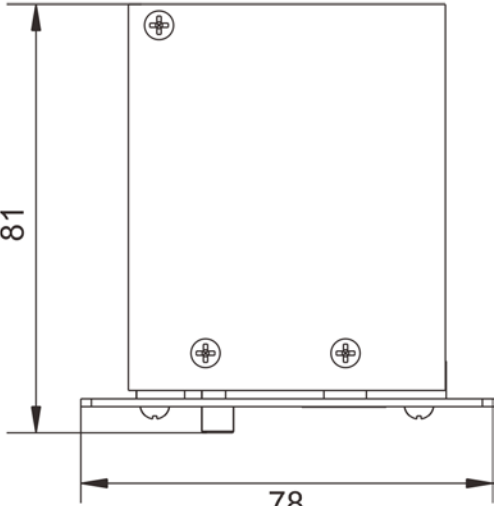

Top view

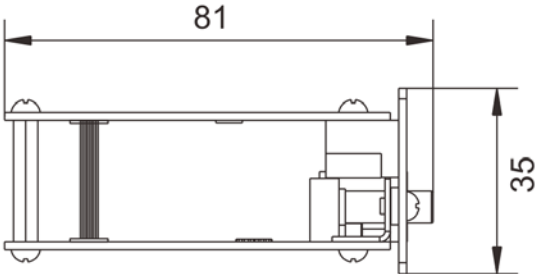

Side view

## ***Chapter 4***

---

### ***System setting by browser***

# Chapter 4: System Setting by Browser

## 4.1 Entering into browser

### 4.1 Entering into browser

Step 1: Please input IP address of the power amplifier network module (factory defaults is 192.168.1.101), then press Enter.

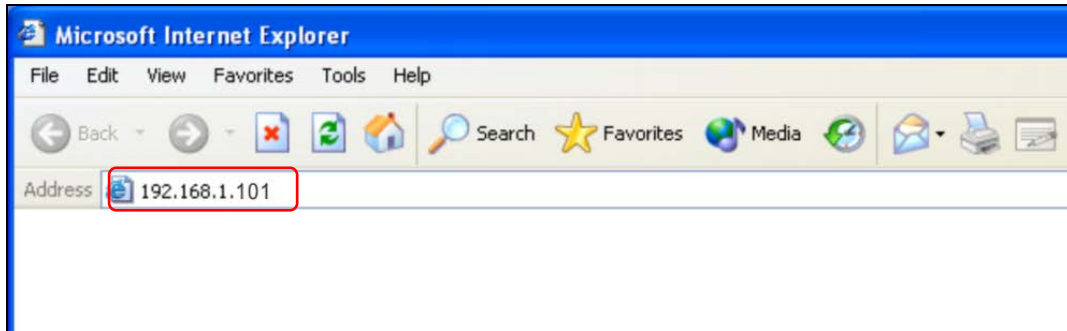

Step 2: Please input the user name and password in the login window of the Web page (the defaults is admin).

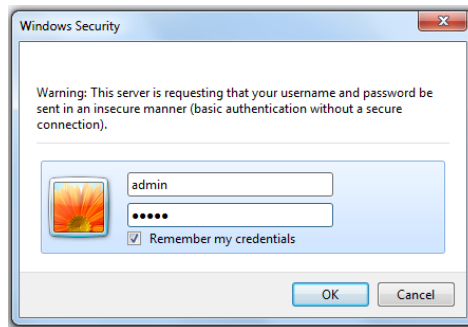

**Note: there is different letter of the user name and password.**

Step 3: It can enter into the Web page after pressed the Enter.

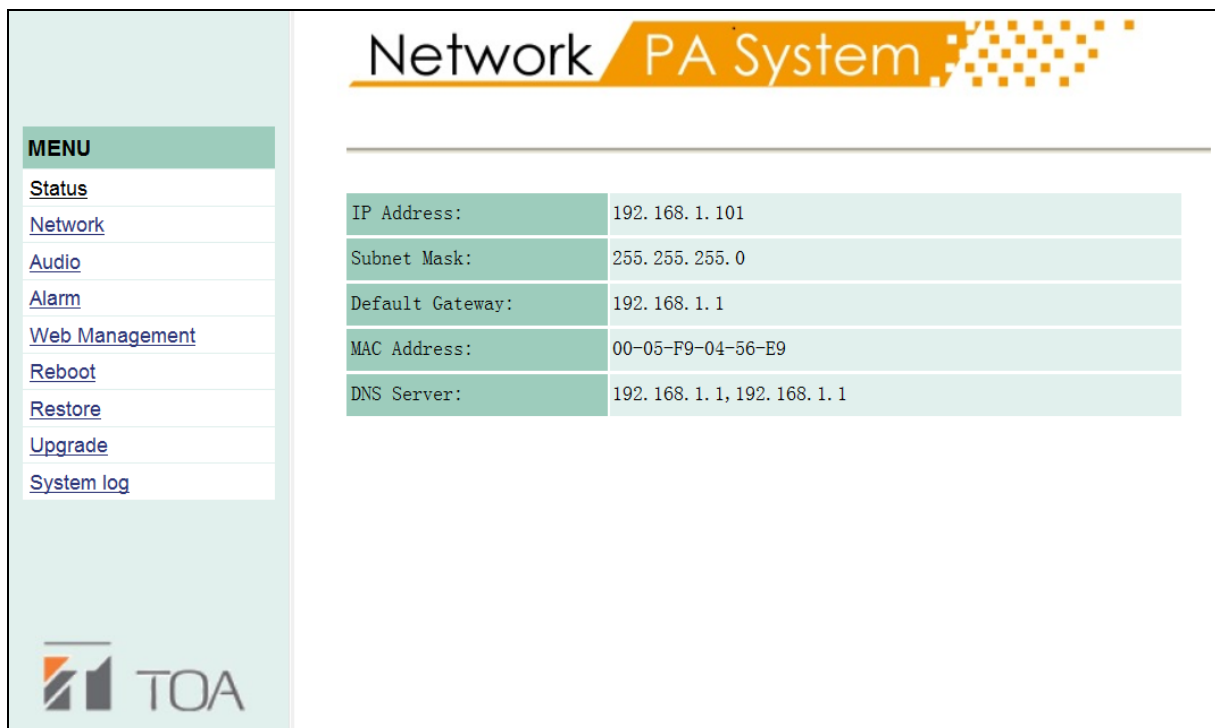

# Chapter 4: System Setting by Browser

## 4.2 Network parameters

### 4.2 Network parameters

**Network parameters**

Device ID:	1
IP Address:	192 . 168 . 1 . 101
Device Port:	2046 (Default:2046)
Subnet Mask:	255 . 255 . 255 . 0
Default Gateway:	192 . 168 . 1 . 1 (Optional)
DNS server1:	192 . 168 . 1 . 1 (Optional)
DNS server2:	192 . 168 . 1 . 1 (Optional)
System Server:	192 . 168 . 1 . 13
System Server Port:	2048 (Default:2048)
Language:	English
HandShake Interval:	30s

Save Default

Device number	Identify the unique number of the speaker and it cannot be repeated with other terminals or hosts.
IP address	IP address of amplifier module
Device port	The defaults port number is 2046, please do not modify it if not in specially situation.
Subnet mask	Please setting subnet mask(the defaults to :255.255.255.0)
Defaults gateway	The gateway of the amplifier module (the defaults is :192.168.1.1)
DNS Server 1	The IP of preferred domain interpreter in the interface unit's network.
DNS Server 2	The IP of standby domain interpreter in the unit's network.
System server	IP address of IP broadcast server
System server port	The defaults sever number is 2048, please don't modify it if not in specially situation.
Language	The Web page of the amplifier's application segment procedure (Firmware) is support for switchover of English and Chinese, but the Web page of bottom segment procedure (BIOS) isn't support for switchover of English and Chinese.
Handshake interval	Setting the interval time between the amplifier and the server.

### 4.3 Audio parameters

Network
PA System

**Audio parameters**

Encoding format:	PCM
Line input volume:	0
Broadcast sampling rate:	22050Hz
Broadcast output volume:	11

**MENU**

- [Status](#)
- [Network](#)
- [Audio](#)
- [Alarm](#)
- [Web Management](#)
- [Reboot](#)
- [Restore](#)
- [Upgrade](#)
- [System log](#)

Coding mode	Broadcast coding, PCM means no data be compressed, ADPCM means packed data (low network data value), display according to the server configuration.
Line input volume	Reserved
Broadcasting sampling rate	Amplifier sampling rate in broadcasting (8000Hz, 22050Hz) .
Broadcast output volume	Amplifier output volume in broadcasting(0~15).

# Chapter 4: System Setting by Browser

## 4.4 WEB management

### 4.4 WEB management

You can modify the account number and password of the login Web page in the Web management parameters.

The screenshot shows a web management interface with a left-hand menu and a main content area. The menu includes options like Status, Network, Audio, Alarm, Web Management (highlighted), Reboot, Restore, Upgrade, and System log. The main content area is titled 'Modify the Web password' and contains a form with five rows of input fields: 'Old user name' (pre-filled with 'admin'), 'Old Password', 'New user name', 'New password', and 'Confirm password'. Below the form are 'Save' and 'Clear' buttons.

MENU	
<a href="#">Status</a>	
<a href="#">Network</a>	
<a href="#">Audio</a>	
<a href="#">Alarm</a>	
<b><a href="#">Web Management</a></b>	
<a href="#">Reboot</a>	
<a href="#">Restore</a>	
<a href="#">Upgrade</a>	
<a href="#">System log</a>	

  

Modify the Web password	
Old user name:	<input type="text" value="admin"/>
Old Password:	<input type="password"/>
New user name:	<input type="text"/>
New password:	<input type="password"/>
Confirm password:	<input type="password"/>



### 4.5 Restarting device

User can click “restart device” to restart the device.

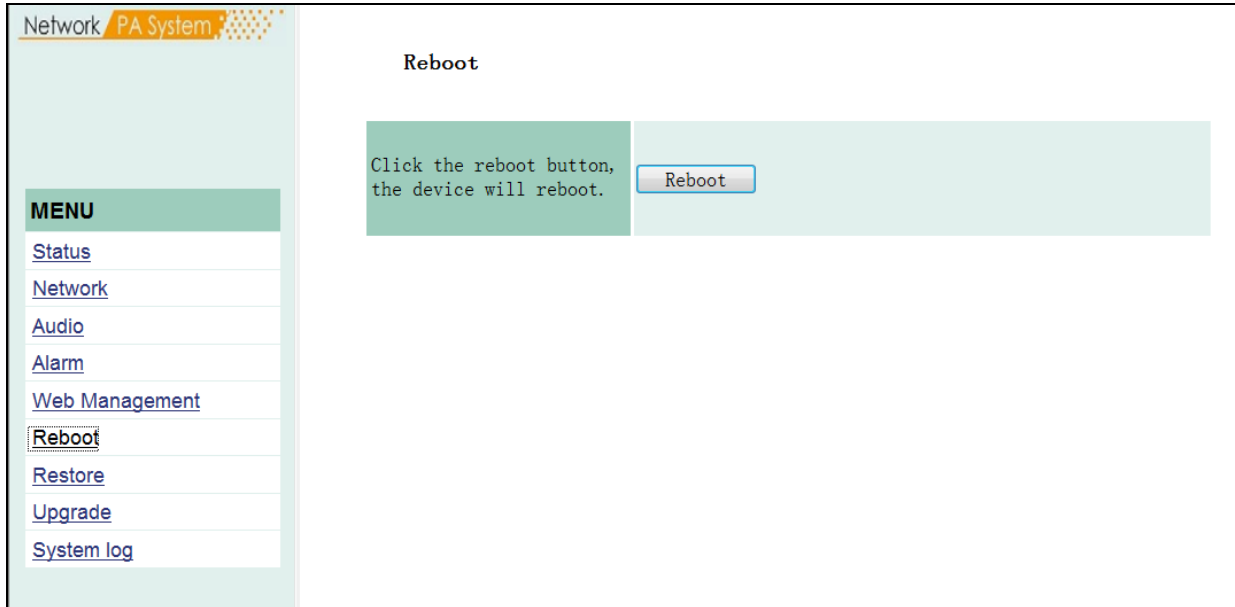

### 4.6 Resetting to defaults

Resetting defaults: all the parameters will reset to defaults.

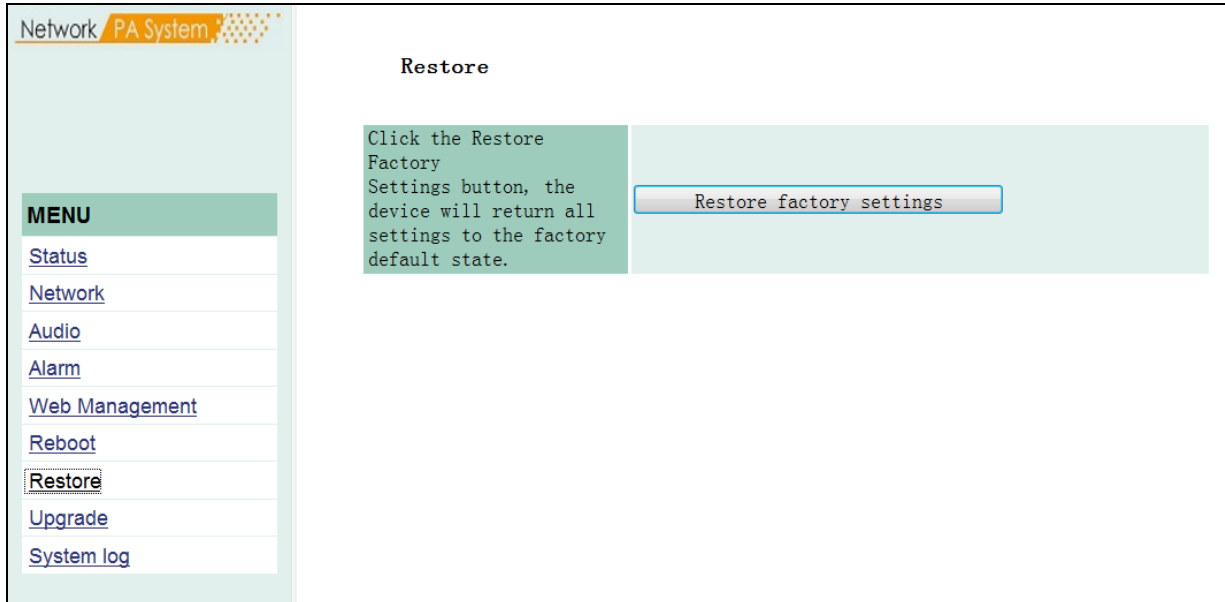

### 4.7 Firmware upgrade

Clicking into the firmware upgrade mode to enter the firmware upgrade interface.

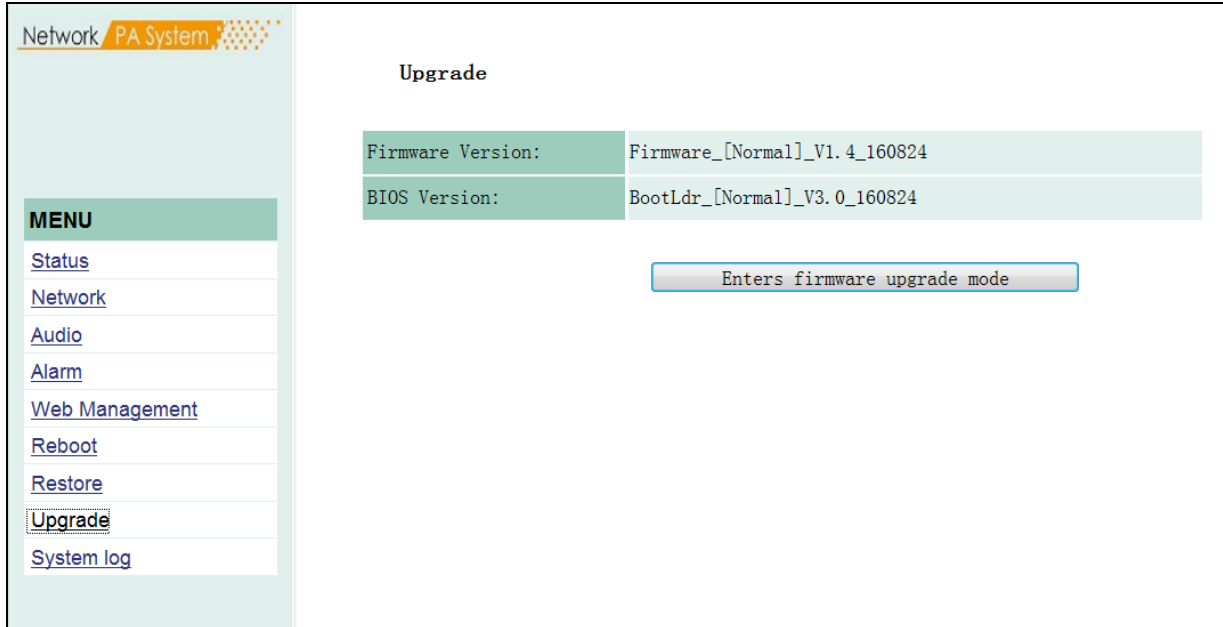

Click browse in the upgrade firmware interface, please select the correct upgrade files, click on "upgrade", it will automatically restart after completed the upgrade.

### 4.8 System log

It can browse the amplifier module log in the Web page, click “delete all logs” can delete all the logs in the Web page.

Network PA System

**MENU**

- Status
- Network
- Audio
- Alarm
- Web Management
- Reboot
- Restore
- Upgrade
- System log

### System Log

Index	The Log Content
1	08-30 15:26:00 Receive broadcasting: 234.0.0.2 : 0
2	08-30 15:26:00 Receive broadcasting: 234.0.0.2 : 0
3	08-30 15:27:00 Logining: 192.168.1.13 : 2048
4	08-30 15:28:00 Soft reset
5	08-30 15:28:00 Reboot
6	08-30 15:28:00 Net status change 1
7	08-30 15:28:00 Logining: 192.168.1.13 : 2048
8	08-30 15:42:00 Net status change 0
9	03-04 00:00:00 Reboot
10	03-04 00:00:00 Net status change 1

1 2 3 4 5 6 7 8 9 10 11 12 13 14 15 16

Refresh Clear All The Log

## ***Chapter 5***

---

### ***Appendix***

#### 5.1.1 Power amplifier network module IP-100XI

<b>Model</b>	IP-100XI
<b>Power</b>	DC24V
<b>Current consumption</b>	<85mA
<b>Relay NC contact</b>	Control voltage≤DC30V,control electric current≤500mA.
<b>Relay COM contact</b>	Control voltage≤DC30V,control electric current≤500mA.
<b>Relay NO contact</b>	Control voltage≤DC30V,control electric current≤500mA.
<b>Network I/F</b>	10BASE-T/100BASE-TX,automatic determination
<b>Network protocol</b>	TCP,UDP,ARP,ICMP,IGMP
<b>Working temperature</b>	0°C~+40°C
<b>Working humidity</b>	Lower than 90%RH (No dew point)

